

Micro cantilever user's manual

Thank you for purchasing OLYMPUS Micro cantilever.
Please read this manual carefully before use.

< Explanation of the each part of the products >

Cantilever chips in a plastic case are included in the envelope with manual and spec. sheet.

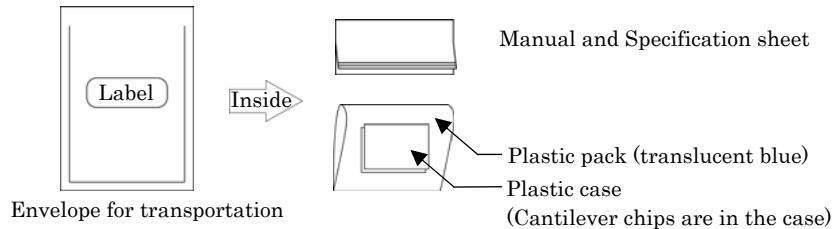

Cantilever chips are contained in the plastic case (Tac carrier)

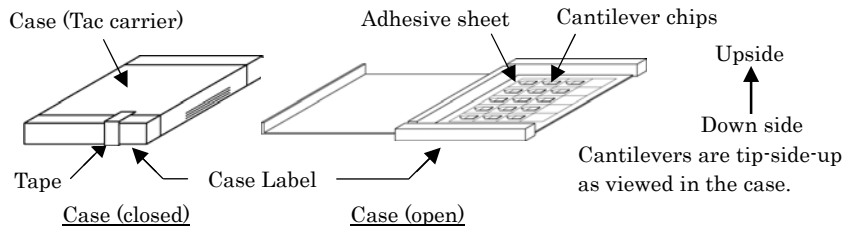

Magnified illust.

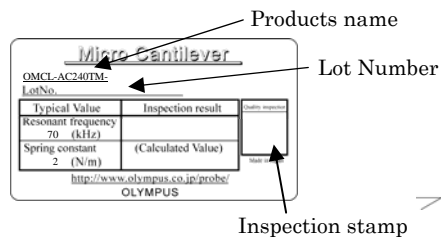

One cantilever elongates from the side of round shoulders of the chip.

OLYMPUS

Please obey the following to the OLYMPUS micro cantilevers

Warning

- Use protective eye glasses when handling to avoid damage to the eyes from breakage of the cantilever chips.



Caution

- Please handle our cantilevers carefully because they are fragile.

Caution

- Do not drop or shake the cantilever case. Even when the cantilever chips are contained in the cantilever case, the cantilevers may break if the case is handled roughly or jarred.

Caution

- It is recommended that precautions be taken to prevent damage to the cantilever tips from electrostatic discharge.

Caution

- Be sure to store the cantilevers at room temperature and moderate humidity.

Caution

- When discarding, please obey the laws and regulations in your country and/or your company. These cantilever are made of silicon, platinum, titanium and aluminum.

Special feature of OLYMPUS Micro cantilever (OMCL-AC240TM-B3/-R3)

1. Platinum coated silicon cantilever

This probe is designed for electrical probing SPM techniques such as EFM, KFM and SCM. Platinum is employed as the coating material which is a precious metal maintains the good conductivity for a long time.

2. Sharp tip

The tip apex is 15 nm (Ave.). The sharp apex will contribute to your high resolution measurements with maintaining the good conductivity.

The platinum layer on the tip has smooth surface so that the tip shape follows the shape of the basic silicon probe. The tetrahedral shape of the basic silicon tip is ideal for achieving a point terminated tip. In addition to the geometric dimensions of the tip, the tip is further sharpened with our exclusive sharpening process.

3. Tip View

The tip is fabricated on the very end of the cantilever. Since the tip isn't hidden by the body of cantilever, it can be positioned exactly at a point of interest using optical microscopy.

'Tip View' is the characteristic common to OMCL-AC series.

4. Aluminum reflex coating

Aluminum showing high reflection is employed as the reflex-coat material. Good S/N ratio can be expected in optical deflection sensing.

5. Pre-separated Chips

Offered in Tac carrier case, the chips are separated and packed individually in advance. The chips can be used in AFM as soon as the case is opened.

See the specification sheet of OLYMPUS Micro cantilevers at the last page of this manual.

Table of contents

	page
1 Preparation	4e
2 Open the case	4e
3 Picking up the cantilever chip from the case	4e
4 Tetrahedral tip	5e
5 Platinum coating	6e
6 Trouble-shooting guide	7e
7 Scope of the Specification	8e
8 Information	9e
9 Specification	1s

1 | Preparation

- 1) Please prepare the followings before using OLYMPUS cantilevers.
- 2) To gain a better understanding of how cantilevers and chips are connected, cantilevers should be inspected under the microscope.

- | | |
|-----------------------------|---|
| 1) Work environment | : <u>Clean bench</u>
(Use of an electrical charge neutralizer or ionizer is recommended.) |
| 2) For hazard avoidance | : <u>Protective eye glasses</u> |
| 3) For cantilever treatment | : <u>Tweezers</u>
(Use of those made of insulator is recommended.)
(Use of anti-electrostatic discharge mat and a wrist band is recommended.) |
| 4) For inspection | : <u>Stereo microscope</u> |

2 | Open the case



- Please handle our cantilevers carefully because they are fragile.



- It is recommended that precautions be taken to prevent damage to the cantilever tips from electrostatic discharge.

- 1) It is recommended that the cantilever case be opened in a clean environment like a clean bench in order to avoid the cantilever being contaminated. Handling under an ionizer is recommended.
- 2) Avoid wearing clothes like woolen sweaters, fleece etc that give off the static electricity when handling the cantilever cases and chips. Use of an anti-electrostatic mat and wrist band is preferable.
- 3) In opening the case, put the plastic case label-side down on a desk.
The cantilevers are tip-side-up as viewed in the case.
- 4) Open the case.

3 | Picking up the cantilever chip from the case



- Avoid any contact with the cantilevers when you pull up the cantilever tip from the case.

- 1) Pick up the chip by the long side with the tweezers and mount it in the AFM.

4 Tetrahedral tip in two stage structure

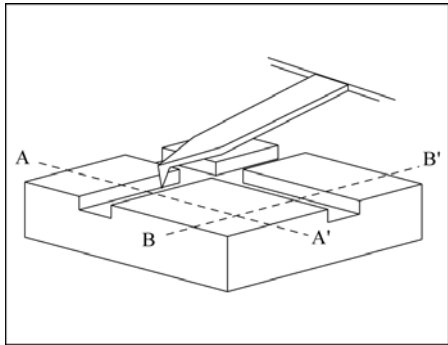

As can be seen in the left illustration, a tetrahedral tip is located at the exact end of the cantilever.

The finite tip shape will determine the scan line profile as in the illustrations below.

The tip profile is symmetric with a half tip angle of 18 degrees macroscopically (see left below).

The side tip profile is asymmetric with a tip angle of 35 degrees. Then the cantilever chip is attached to a chip holder in your AFM with an angle, about 10 degrees, the asymmetry is improved (see right below).

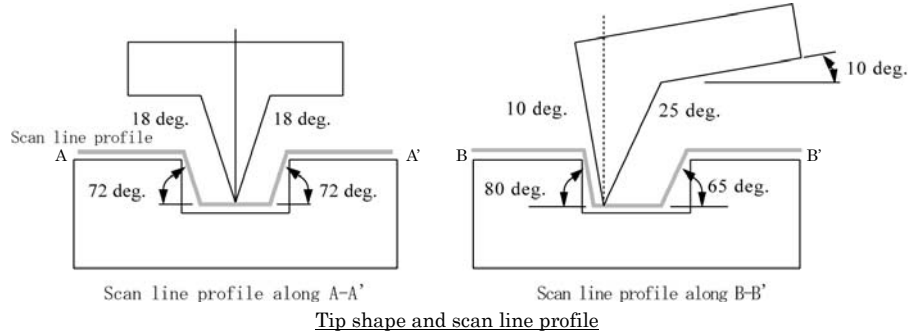

The apex of the tetrahedral tip becomes sharper due to an oxide sharpening process. The tip angle around a few hundreds nano meter down from the top, is about 15 to 25 degrees (see below).

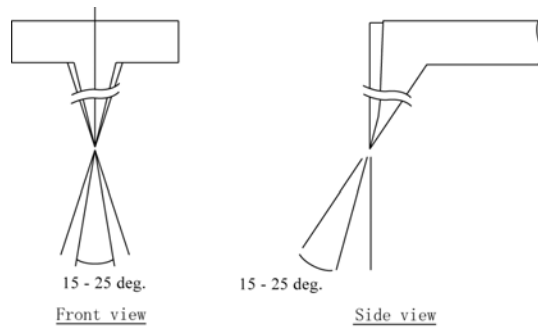

5 Platinum coating

When you set your samples to your instrument, please consider the unique shape of the tetrahedral tip, that is 'good symmetry', when viewing from front side and choose the direction of the sample. When measuring long grooves, you can get an idea of what angle of the cut will be quickly by aligning the cantilever along the grooves and scanning across at right angles against grooves (see below).

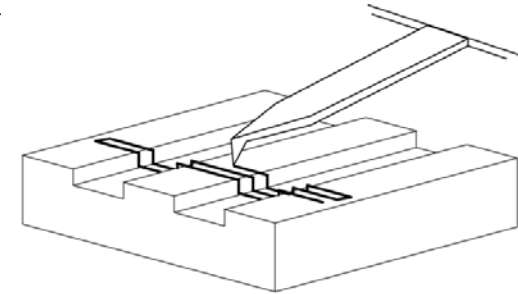

Cantilever, sample and fast scan direction

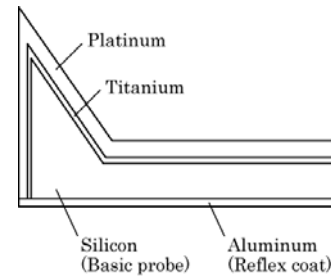

As can be seen in the left illustration, the platinum layer is deposited on the basic silicon probe with the titanium interfacial layer. The platinum layer around the probe apex is thinner than that on the cantilever portion. In the spec sheet, the typical value on the flat part as the cantilever portion is described.

In attaching the chip to your SPM instrument, electrically connect to the chip in the cantilever side for stable measurements (see illustration below). It is not expected that the aluminum layer shows enough conductivity because the surface of the aluminum layer is covered with oxide layer.

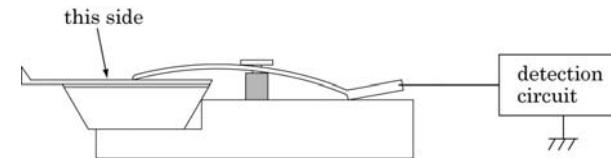

Situations as described below may arise when using this type of cantilever.

Case1: In adjusting the sensor optics before scanning, the movement of the reflection spot on the photo detector is critical so that the sensor optics is hard to adjust to zero position. When the sensor illumination spot on the cantilever is not small enough and is positioned at the triangular part of the cantilever, unexpected reflection and light scattering occur. This may cause the unexpected movement of the reflection spot on the photo detector.

Solution:

Try to adjust the focus of the sensor optics again and move the spot position a little opposite to the free end of the cantilever.

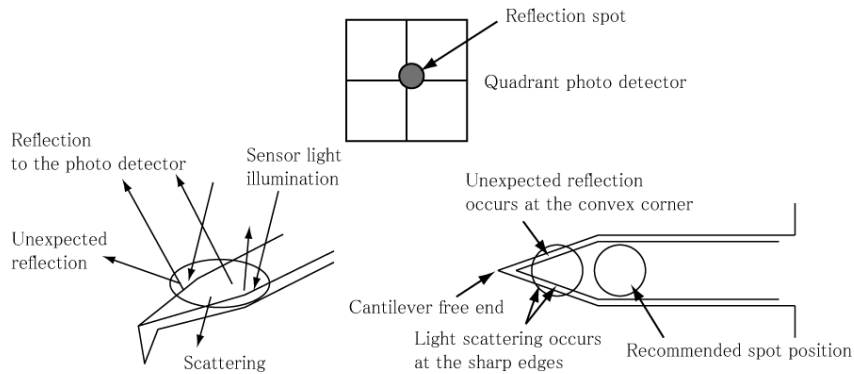

Case2: The electric images turn to vague and low in contrast after several scans in EFM. Even in AC mode operations as EFM, the probe touches the sample surface and the platinum coating may wear.

Solution:

Once platinum layer has worn extremely, the cantilever should be replaced. Since this case is found frequently, look the servo condition of your SPM again.

Case3: The electric images of an IC device turn to high contrast after the several scans in SCM. The worn of the platinum coating is suspected. In SCM of IC devices, the signal is depending on the density of the dopant. Blunt probe may interact with more dopants and get higher electric signals.

Solution:

In the case that the platinum layer has worn extremely, even if higher signal is obtained, it is recommended that the cantilever is replaced. Please check the lateral resolution of the image as well as the signal contrast. Those are trade-off.

1) Break-down voltage

Spec:

The break-down voltage is not guaranteed.

Note:

In our experiment using a gold-coated sample illustrated below, break-down occurred at 3 volts and 7mA. In case of dielectric material, break-down wasn't found at 50 volts. Note that the tip loading force was roughly regulated in those experiments.

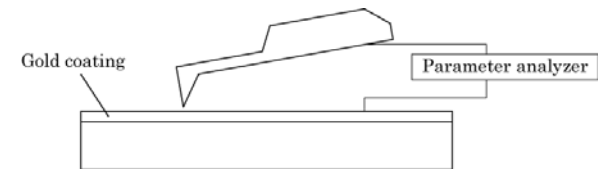

2) Actual resistivity of the probe

Spec:

The actual resistivity of the probe is not guaranteed.

Note:

In our inspection illustrated right, wiring resistivity ($1000 \mu m \times 400 \mu m$) of the chip was checked.

The inspection was done for 5 wiring resistivity of chips sampled from a wafer. When all the 5 chips met the inspection spec, the wafer was regarded as good wafer and a designated number of chips were extracted from the wafer and placed in the plastic case.

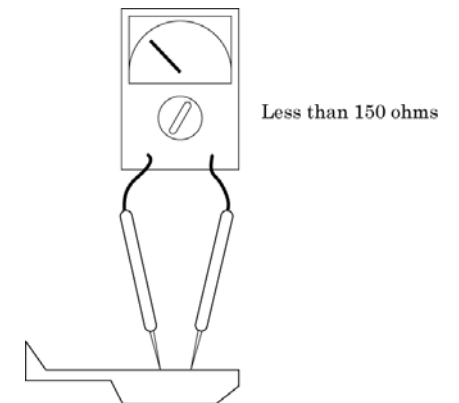

Please contact following if you have any question on this user's manual.

OLYMPUS CORPORATION

Microtechnology R&D Division

2-3 Kuboyama-cho Hachioji-shi Tokyo 192-8512 Japan

email : probe@olympus.co.jp

Please access to the web page of OLYMPUS micro cantilevers.

<http://www.olympus.co.jp/probe>

Ver.1.0 Dec 18, 2009
OLYMPUS CORPORATION